



Series
MPX

SIZE 5 SOCKET COAXIAL CONTACT
FOR RG 142, RG 400 AND RG 223 CABLES

Issue:
21 OCT.98

Page
1 / 2

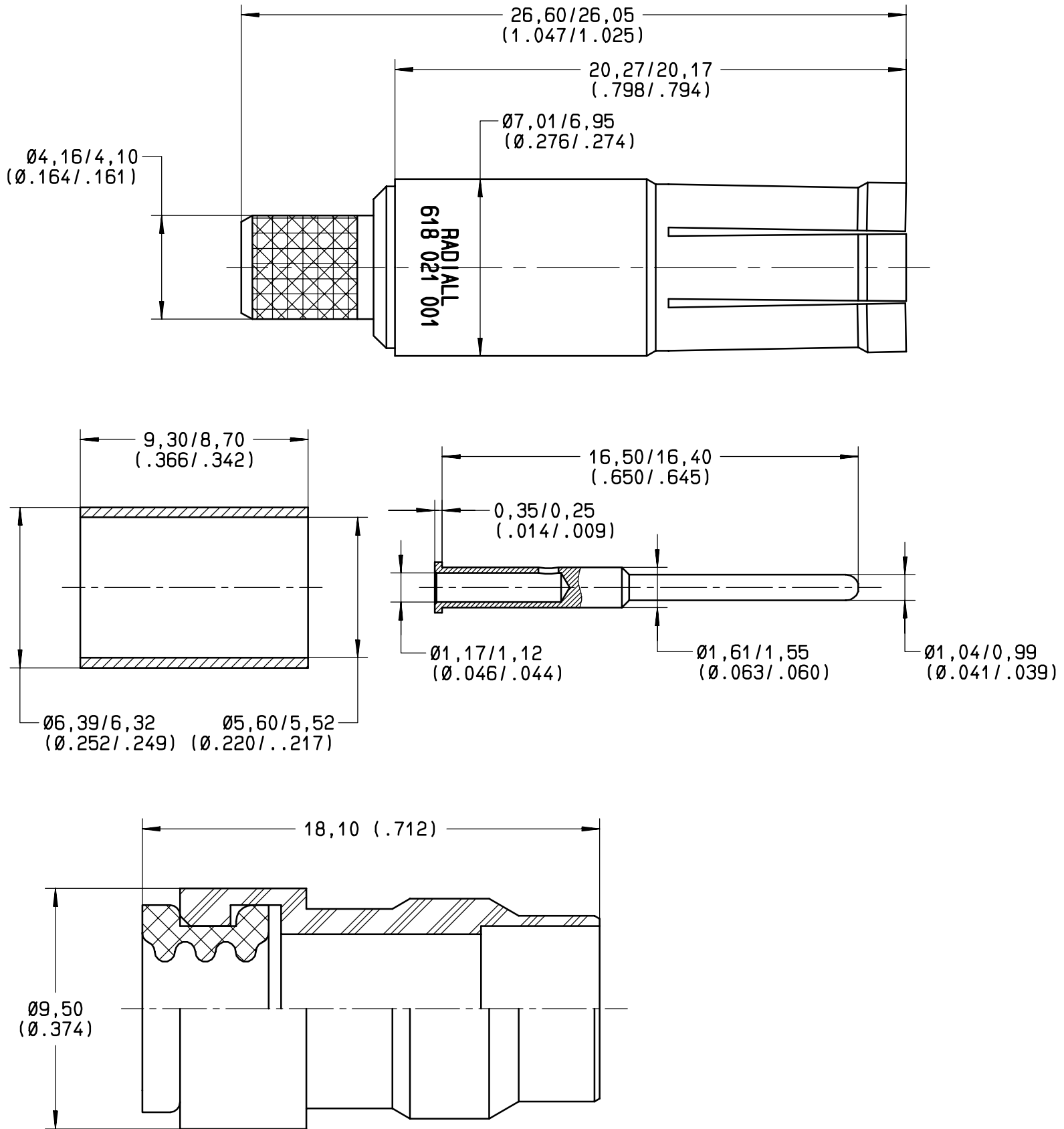

***MATERIAL:**

- CONTACT: BODY: BERYLIUM COPPER PER ASTM-B-196
CENTER CONTACT AND FERRULE: ANNEAL BRASS
- SEALING BOOTH: FLUOROSILICONE ELASTOMER PER MIL-R-25988 OR PER ZZ-R-765

***FINISH:**

- ALL METALLIC PARTS: PLATING .00005 INCH OF GOLD PER MIL-G-45204 TYPE I OR II GRADE C OR D CLASS 1 OVER NICKEL PER QQ-N-290

This information is given as an indication. In the continual goal to improve our products, we reserve the right to make any modifications judged necessary.

4112-9610

CREATION				
PEN: .				
NOM: MACARI				
DATE: 21 OCT.98				
APPR.: .				
Issue	Revisions	Name	Approved	

RADIALL[®]

101, rue Philibert Hoffmann Z.I. Ouest
93116 ROSNY/BOIS Cedex (France)
Tl.: 01 49 35 35 35
Fax.: 01 48 54 63 63
Tlax: RADIA 235220



WIRING INSTRUCTION

STEP 1/
SLIDE SEALING BOOTH OVER CABLE

STEP 2/
SLIDE FERRULE OVER OUTER JACKET, NEXT TRIM OUTER JACKET, BRAID AND DIELECTRIC TO DIMENSIONS SHOWN

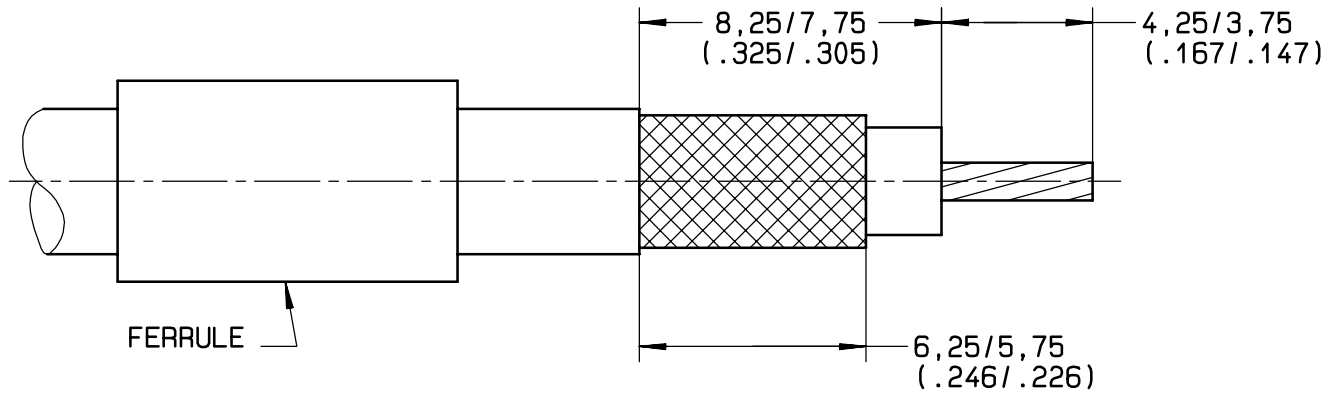

STEP 3/
SLIDE CENTER CONTACT OVER INNER CONDUCTOR AND CRIMP USING:
CRIMPING TOOL: M22520/2.01 (RADIALL 282281)
SELECTOR ON 6 FOR RG400
ON 8 FOR RG142 AND RG223
POSITIONER: DANIELS K345 (RADIALL 282550)

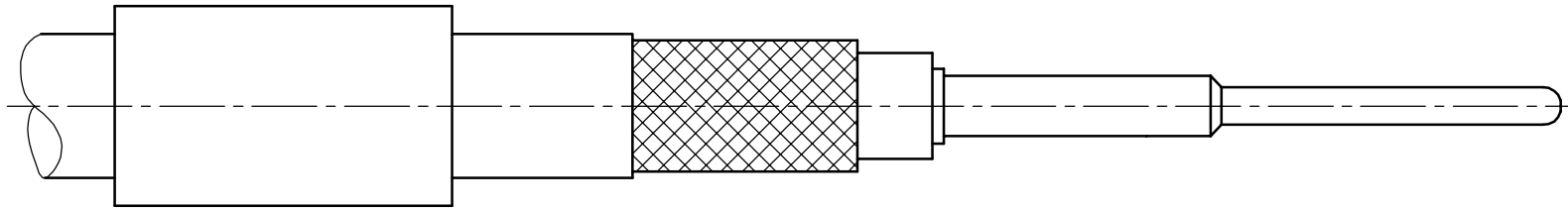

STEP 4/
FLARE BRAID AND SLIDE OUTER CONTACT UNDERNEATH

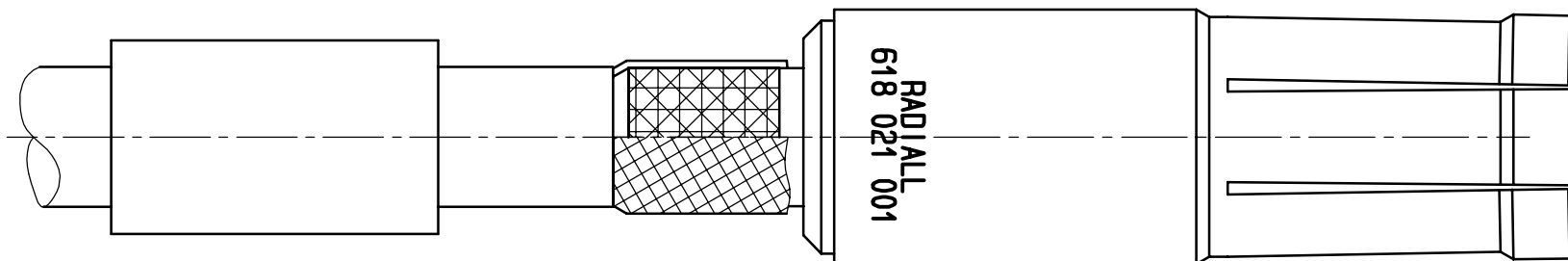

STEP 5/
SLIDE FERRULE OVER BRAID AND CRIMP FERRULE OVER OUTER CONTACT USING:
CRIMPING TOOL: M22520/5.01 (RADIALL 282293)
DIE: M22520/5.05 (RADIALL 282246) HEX B

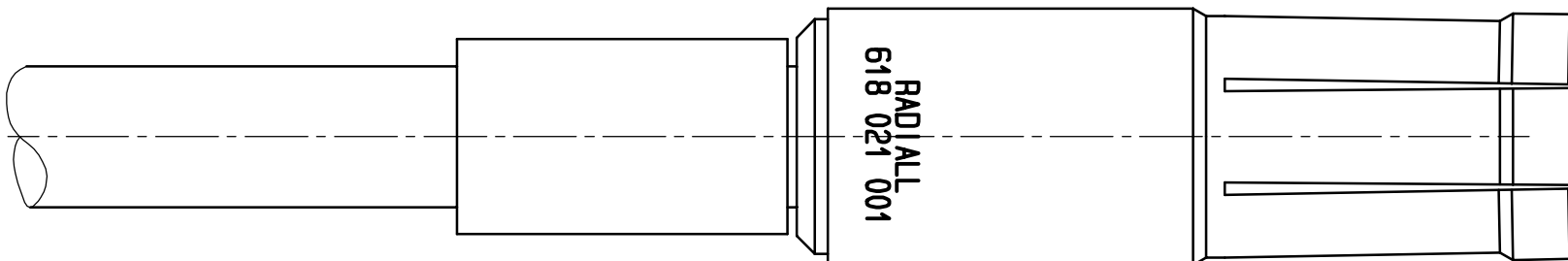

This information is given as an indication. In the continual goal to improve our products, we reserve the right to make any modifications judged necessary.